

MA251 (de_en) Bedienungsanleitung

Crimpzange PV-CZM

Inhalt

Sicherheitshinweise	2
Ausführung für MC4	3
Ausführung für MC4-Evo 2	6
Crimpeinsatz auswechseln	8
Crimpen	10

MA251 (de_en) Operating instructions

Crimping pliers PV-CZM

Content

Safety Instructions	2
Explanation for MC4	3
Explanation for MC4-Evo 2	6
Exchanging the crimping die.....	8
Crimping.....	10



Sicherheitshinweise

Diese Montageanleitung und die darin beschriebenen Montageschritte und -hinweise sind Bestandteil bzw. Voraussetzung der Zertifizierungen durch TÜV und UL.

Stäubli Electrical Connectors (Stäubli) lehnt jegliche Haftung infolge Nichteinhaltung dieser Warnhinweise ab.

Safety instructions

These assembly instructions and the assembly steps and instructions described are an integral part of and prerequisite for certification by TÜV and UL.

Stäubli Electrical Connectors (Stäubli) does not accept any liability in the event of failure to observe these warnings.



IEC 60417-6182
Installation, elektrotechnisches Fachwissen

Die Montage und Installation der Produkte darf ausschließlich durch Elektrofachkräfte oder elektrotechnisch unterwiesene Personen unter Berücksichtigung aller anwendbaren gesetzlichen Sicherheitsbestimmungen und Regelungen erfolgen.

Installation, electrotechnical expertise

The products may be assembled and installed by electrically skilled or instructed persons duly observing all applicable safety regulations.



IEC 60417-6042
Vorsicht, Gefahr des elektrischen Schlags

Steckerverarbeitung im spannungsfreien Zustand. Die fünf Sicherheitsregeln sind bei Arbeiten an elektrischen Installationen zu beachten.

Nachdem die betroffenen Anlagenteile festgelegt sind, müssen die folgenden fünf wesentlichen Anforderungen in der angegebenen Reihenfolge eingehalten werden, sofern es nicht wichtige Gründe gibt, davon abzuweichen:

- Freischalten;
- gegen Wiedereinschalten sichern;
- Spannungsfreiheit feststellen;
- Erden und kurzschließen;
- benachbarte, unter Spannung stehende Teile abdecken oder abschranken.

Alle an der Arbeit beteiligten Personen müssen Elektrofachkräfte oder elektrotechnisch unterwiesene Personen sein oder unter Aufsichtsführung einer solchen Person stehen.

Quelle: EN 50110-1:2013 (DIN EN 50110-1, VDE 0105-1)

Der Schutz gegen elektrischen Schlag ist auch in den Endanwendungen zu prüfen.

Caution, risk of electric shock

Perform connector preparation in a de-energized state. Follow the five safety rules, when working on electrical installations.

After the respective electrical installations have been identified, the following five essential requirements shall be undertaken in the specified order unless there are essential reasons for doing otherwise:

- disconnect completely;
- secure against re-connection;
- verify absence of operating voltage;
- carry out earthing and short-circuiting;
- provide protection against adjacent live parts.

Any person engaged in this work activity shall be electrically skilled or instructed, or shall be supervised by such a person.

Source: EN 50110-1:2013

Protection against electric shock shall be checked in the end-use applications too.



ISO 7000-0434B
Vorsicht

Vor jedem Gebrauch ist visuell zu prüfen, ob keine äußeren Mängel vorhanden sind. Wenn Zweifel bezüglich der Sicherheit bestehen, muss ein Fachmann hinzugezogen werden.

Einsatz nur entsprechend der in den technischen Daten angegebenen Spezifikation (siehe Produktkatalog).

Der Anwender ist selbst verantwortlich für das Tragen einer an die jeweilige Tätigkeit angepasste Schutzausrüstung.

Komponenten und Verpackungsmaterial sind kein Spielzeug, Gefahr vor Verschlucken von Kleinteilen. Erstickungsgefahr beim Umgang mit Verpackungsmaterial.

Bestimmungsgemäße Entsorgung der Produkte und Verpackungsmaterialien nach Gebrauch.

Caution

Each time the connector is used, it should previously be inspected for external defects. If there are any doubts as to its safety, a specialist must be consulted.

Use only in accordance with the specification provided in the technical data (see product catalog).

The wearing of suitable protective equipment or the performance of the relevant work is the responsibility of the user.

Components and packaging materials are not toys; small parts can pose a choking hazard if swallowed. Packaging material can pose a risk of suffocation.

Proper disposal of products and packaging materials after use.



IEC 60417-6070
Nicht unter Last trennen

Trennung unter Last: PV-Steckverbinder dürfen nicht unter Last getrennt werden.

Im Leerlaufbetrieb ist das Stecken und Trennen unter Spannung zulässig (durch Abschaltung des DC/AC Wandlers oder Unterbrechung des AC Stromkreises).

Do not disconnect under load

Disconnect Under Load: PV plug connections must not be disconnected while under load.

During no-load operation plugging and unplugging when live is permitted (by switching off the DC/AC converter or breaking the AC circuit).

Ausführung für MC4

Explanation for MC4

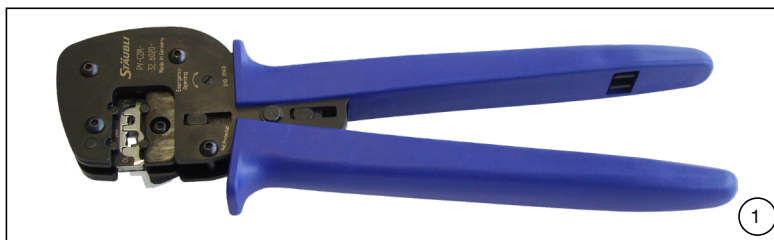

(ill. 1) Crimpzange inkl. Lokator und eingebautem Crimpeinsatz

(ill. 1) Crimping pliers incl. locator and built-in crimping die

Typ Type	Leiterquerschnitt Conductor cross section	Offener Crimpkontakt (B-Crimp) Open barrel crimp (B-Crimp)	Geschlossener Crimpkontakt (O-Crimp) Closed barrel crimp (O-Crimp)	Crimpzangen Crimping pliers						Crimpeinsätze Crimping dies						Lokator Locator		
				PV-CZM-18100 32.6020-18100	PV-CZM-19100 32.6020-19100	PV-CZM-22100 32.6020-22100	PV-CZM-23100 32.6020-23100	PV-CZM-20100 32.6020-20100	PV-CZM-21100 32.6020-21100	PV-ES-CZM-18100 32.6021-18100	PV-ES-CZM-19100 32.6021-19100	PV-ES-CZM-22100 32.6021-22100	PV-ES-CZM-23100 32.6021-23100	PV-ES-CZM-20100 32.6021-20100	PV-ES-CZM-21100 32.6021-21100	PV-LOC 32.6040	PV-LOC-B 32.6055	PV-LOC-D 32.6074
PV-KBT4/2,5...-UR, PV-KST4/2,5...-UR	2.5 mm ²	•		•	•					•	•					•		
	14 AWG	•		•	•					•	•					•		
PV-KBT4/6...-UR, PV-KST4/6...-UR	4 mm ²	•		•	•	•		•		•	•	•		•		•	•	
	12 AWG	•		•	•	•		•		•	•	•		•		•	•	
	6 mm ²	•			•	•			•		•	•			•	•	•	
PV-KBT4/5...-UR, PV-KST4/5...-UR	10 AWG	•			•	•					•	•			•	•	•	
	14 AWG		•				•											•
PV-KBT4/5...-UR, PV-KST4/5...-UR	12 AWG		•				•											•
	10 AWG		•				•											•
PV-KBT4/8I-UR, PV-KST4/8I-UR	8 AWG		•		•	•						•	•					•
PV-KBT/10... PV-KST/10...	10 mm ²	•						•	•						•	•		

Pos.	Leiterquerschnitt Cable cross section		geeignet für suitable for
	mm ²	AWG	
1	1,5	14	PV-KST4/2.5-UR PV-KBT4/2.5-UR
2	2,5		PV-KST4/2.5-UR PV-KBT4/2.5-UR
3	4	12	PV-KST4/6-UR PV-KBT4/6-UR

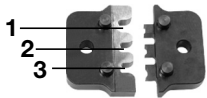

(2)

Einzelteile

(ill. 2 + 3 + 4 + 5 + 6)
Auswechselbare Crimpeinsätze

Individual parts

(ill. 2 + 3 + 4 + 5 + 6)
Interchangeable crimping dies

(ill. 2)

Crimpbereich Crimping range		Typ Type	Bestell-Nr. Order No.
mm ²	AWG		
1,5/2,5/4	14/12	PV-ES-CZM-18100	32.6021-18100

(ill. 2)

Pos.	Leiterquerschnitt Cable cross section		geeignet für suitable for
	mm ²	AWG	
4	2,5		PV-KST4/2.5...-UR PV-KBT4/2.5...-UR
5	4	12	PV-KST4/6...-UR PV-KBT4/6...-UR
6	6	10	PV-KST4/6...-UR PV-KBT4/6...-UR

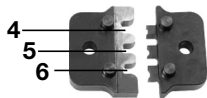

(3)

(ill. 3)

Crimpbereich Crimping range		Typ Type	Bestell-Nr. Order No.
mm ²	AWG		
2,5/4/6	12/10	PV-ES-CZM-19100	32.6021-19100

(ill. 3)

Pos.	Leiterquerschnitt Cable cross section		geeignet für suitable for
	mm ²	AWG	
7	4		PV-KST4/6...-UR PV-KBT4/6...-UR
8	10		PV-KST4/10...-UR PV-KBT4/10...-UR

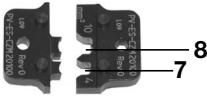

(4)

(ill. 4)

Crimpbereich Crimping range		Typ Type	Bestell-Nr. Order No.
mm ²	AWG		
4/10		PV-ES-CZM-20100	32.6021-20100

(ill. 4)

Pos.	Leiterquerschnitt Cable cross section		geeignet für suitable for
	mm ²	AWG	
9	6		PV-KST4/6...-UR PV-KBT4/6...-UR
10	10		PV-KST4/10...-UR PV-KBT4/10...-UR

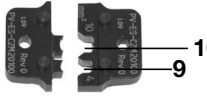

(5)

(ill. 5)

Crimpbereich Crimping range		Typ Type	Bestell-Nr. Order No.
mm ²	AWG		
6/10		PV-ES-CZM-21100	32.6021-21100

(ill. 5)

Pos.	Leiterquerschnitt Cable cross section	geeignet für suitable for
	AWG	
11	8	PV-KST4/8II-UR PV-KBT4/8II-UR
12	10	PV-KST4/6...-UR PV-KBT4/6...-UR
13	12	PV-KST4/6...-UR PV-KBT4/6...-UR



(6)

(ill. 6)

(ill. 6)

Crimpbereich Crimping range	Typ Type	Bestell-Nr. Order No.
AWG		
8/12/10	PV-CZM-22100	32.6020.22100

Pos.	Leiterquerschnitt Cable cross section	geeignet für suitable for
	AWG	
14	8	PV-KST4/8II-UR PV-KBT4/8II-UR
15	10/12	PV-KST4/5...-UR PV-KBT4/5...-UR
16	14	PV-KST4/5...-UR PV-KBT4/5...-UR

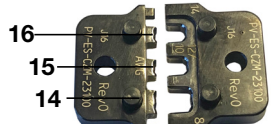

(7)

(ill. 7)

(ill. 7)

Crimpbereich Crimping range	Typ Type	Bestell-Nr. Order No.
AWG		
8/10/12/14	PV-CZM-23100	32.6021-23100



(ill. 8)

(ill. 8)

Lokator PV-LOC
Bestell-Nr.: 32.6040

Locator PV-LOC
Order No.: 32.6040



(ill. 9)

(ill. 9)

Lokator PV-LOC-B
Bestell-Nr.: 32.6055

Locator PV-LOC-B
Order No.: 32.6055

Hinweis:
i Beim Einsatz des Crimpwerkzeuges PV-CZM-22100 Lokator PV-LOC-B benutzen.

Note:
i When using the crimping pliers PV-CZM-22100, use the locator PV-LOC-B.

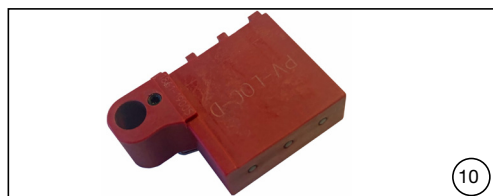

(ill. 10)

(ill. 10)

Lokator PV-LOC-D
Bestell-Nr.: 32.6074

Locator PV-LOC-D
Order No.: 32.6074

Hinweis:
i Beim Einsatz des Crimpwerkzeuges PV-CZM-23100 Lokator PV-LOC-D benutzen.

Note:
i When using the crimping pliers PV-CZM-23100, use the locator PV-LOC-D.

Ausführung für MC4-Evo 2

Explanation for MC4-Evo 2



(ill. 11)
Crimpzange inkl. Lokator und eingebautem Crimpeinsatz

(ill. 1)
Crimping pliers incl. locator and built-in crimping die

Typ Type	Leiterquerschnitt Conductor cross section	Offener Crimpkontakt (B-Crimp) Open barrel crimp (B-Crimp)	Geschlossener Crimpkontakt (O-Crimp) Closed barrel crimp (O-Crimp)	Crimpzangen Crimping pliers			Crimpeinsätze Crimping dies			Lokator Locator
				PV-CZM-40100 32.6020-40100	PV-CZM-41100 32.6020-41100	PV-CZM-42100 32.6020-42100	PV-ES-CZM-40100 32.6021-40100	PV-ES-CZM-41100 32.6021-41100	PV-ES-CZM-42100 32.6021-42100	
PV-KST-EVO 2/2.5...-UR	2.5 mm ²	•		•	•		•	•		•
PV-KBT-EVO 2/2.5...-UR	14 AWG	•		•	•		•	•		•
PV-KST-EVO 2/6...-UR, PV-KBT-EVO 2/6...-UR	4 mm ²	•		•	•	•	•	•	•	•
	12 AWG	•		•	•	•	•	•	•	•
	6 mm ²	•		•	•	•	•	•	•	•
PV-KST-EVO 2/10...-UR, PV-KBT-EVO 2/10...-UR	10 AWG	•		•	•	•	•	•	•	•
	10 mm ²	•				•			•	•
	8 AWG	•				•			•	•

Pos.	Leiterquerschnitt Cable cross section		geeignet für suitable for
	mm ²	AWG	
1	1,5		PV-KST4-EVO 2/2,5...-UR PV-KBT4-EVO 2/2,5...-UR
2	2,5	14	PV-KST4-EVO 2/2,5...-UR PV-KBT4-EVO 2/2,5...-UR
3	4	12	PV-KST4-EVO 2/6...-UR PV-KBT4-EVO 2/6...-UR

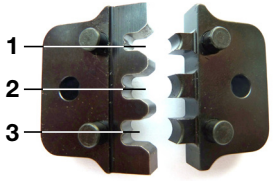

(12)

Pos.	Leiterquerschnitt Cable cross section		geeignet für suitable for
	mm ²	AWG	
4	2,5	14	PV-KST4-EVO 2/2,5...-UR PV-KBT4-EVO 2/2,5...-UR
5	4	12	PV-KST4-EVO 2/6...-UR PV-KBT4-EVO 2/6...-UR
6	6	10	PV-KST4-EVO 2/6...-UR PV-KBT4-EVO 2/6...-UR

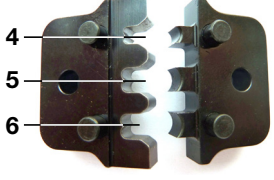

(13)

Pos.	Leiterquerschnitt Cable cross section		geeignet für suitable for
	mm ²	AWG	
7	4	12	PV-KST4-EVO 2/6...-UR PV-KBT4-EVO 2/6...-UR
8	10	8	PV-KST4-EVO 2/10...-UR PV-KBT4-EVO 2/10...-UR

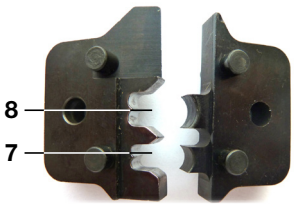

(14)

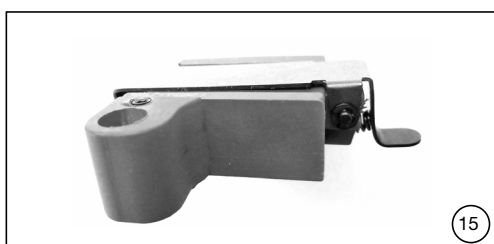

Einzelteile

(ill. 12 + 13 + 14)
Auswechselbare Crimpeinsätze

(ill. 12)

Crimpbereich Crimping range		Typ Type	Bestell-Nr. Order No.
mm ²	AWG		
1,5/2,5/4	14/12	PV-ES-CZM-40100	32.6021-40100

Individual parts

(ill. 12 + 13 + 14)
Interchangeable crimping dies

(ill. 12)

(ill. 13)

Crimpbereich Crimping range		Typ Type	Bestell-Nr. Order No.
mm ²	AWG		
2,5/4/6	14/12/10	PV-ES-CZM-41100	32.6021-41100

(ill. 13)

(ill. 14)

Crimpbereich Crimping range		Typ Type	Bestell-Nr. Order No.
mm ²	AWG		
4/10	12/8	PV-ES-CZM-42100	32.6021-42100

(ill. 14)

(ill. 15)
Lokator PV-LOC-C
Bestell-Nr.: 32.6056

(ill. 15)
Locator PV-LOC-C
Order no.: 32.6056

Crimpeinsatz auswechseln

Exchanging the crimping die

Crimpeinsatz ausbauen

Removing the crimping die

(ill. 16)
Crimpzange schließen.

(ill. 16)
Close the crimping pliers.

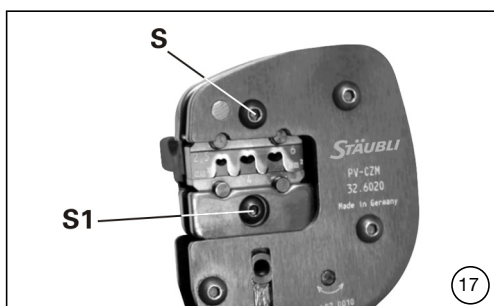

(ill. 17)
Schraube S (lang) und S1 (kurz) komplett herausdrehen.
Crimpzange öffnen (ganz zusammen-drücken und loslassen).

(ill. 17)
Remove completely both mounting screws: the long S and the short S1.
Open the crimping pliers (press completely together and release).



(ill. 18)
Oberen Crimpeinsatz herausnehmen.

(ill. 18)
Remove the upper crimping die.



(ill. 19)
Unteren Crimpeinsatz herausnehmen.

(ill. 19)
Remove the lower crimping die.

Crimpeinsatz einbauen



(ill. 20)

- Crimpzange öffnen (ganz zusammen-drücken und loslassen).
- Beide Crimpeinsätze einführen.
- Die Beschriftung muss sich auf der gleichen Seite wie die Beschriftung der Crimpzange befinden.
- Crimpzange schliessen und beide Crimpeinsätze festschrauben.
- Schraube an ihrer richtigen Stelle platzieren. Schraubenköpfe nicht verletzen.

Fitting the crimping die

(ill. 20)

- Open the crimping pliers (press completely together and release).
- Insert both crimping dies.
- The markings must be on the same side as the marking on the crimping pliers.
- Close crimping pliers and screw both crimping dies.
- But take care not to strip screw heads and to put each screw in its proper location.

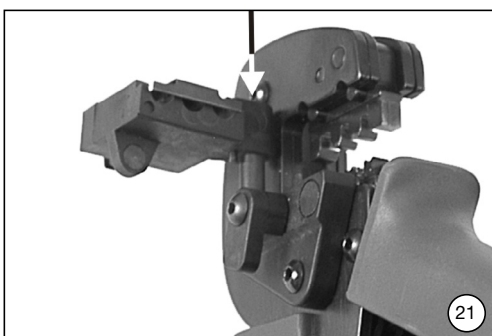

(ill. 21)

Lokator in den Führungsstift einlegen.

(ill. 21)

Affix locator onto the guide pin.

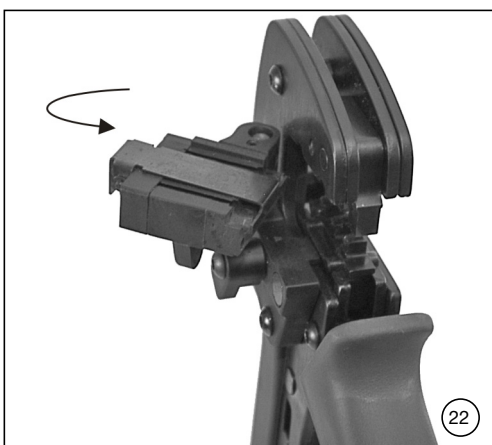

(ill. 22)

Lokator umschwenken (wird magnetisch festgehalten).

(ill. 22)

Rotate the locator (held magnetically)

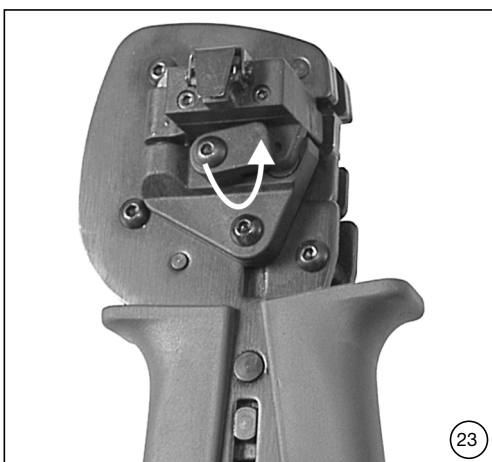

(ill. 23)

Lokator verriegeln.

(ill. 23)

Lock the locator.

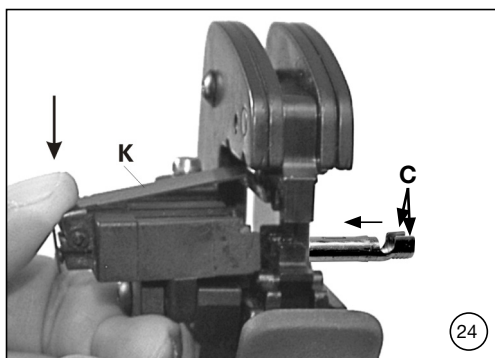

Crimpen

(ill. 24)

- Klemmbügel (K) öffnen und festhalten.
- Kontakt in den passenden Querschnittsbereich legen.
- Crimplaschen (C) nach oben drehen.
- Klemmbügel (K) loslassen.
- Der Kontakt ist fixiert.

Crimping

(ill. 24)

- Open and hold clamp (K).
- Place the contact in the appropriate cross-section range.
- Turn the crimping flaps (C) upwards.
- Release clamp (K).
- The contact is fixed.

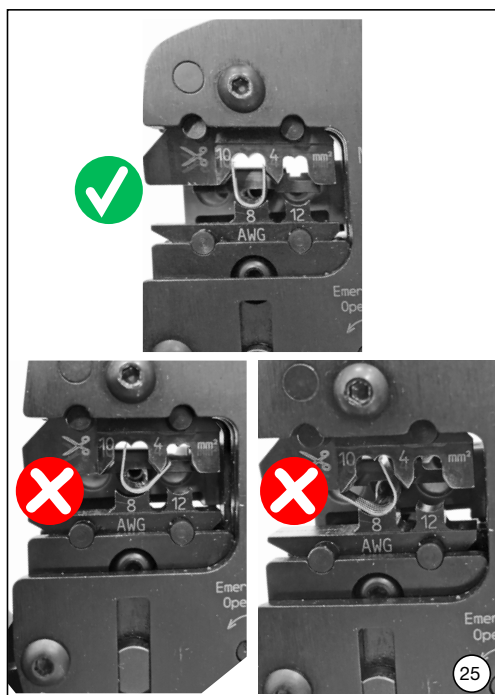

(ill. 25)

Prüfen, ob die Crimplaschen noch richtig ausgerichtet sind.

Zange leicht zusammendrücken, so dass die Crimplaschen innerhalb des Crimpeinsatzes liegen.

(ill. 25)

Verify if the crimping flaps are still correctly aligned.

Press the pliers gently together until the crimping flaps are properly located within the crimping die.

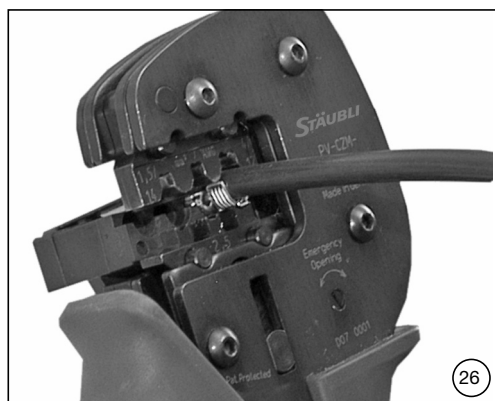

(ill. 26)

Abisoliertes Kabel einführen, bis die Litzen am Klemmbügel anschlagen. Crimpzange ganz schließen.

(ill. 26)

Insert the stripped cable end until the cable strands come up against the clamp. Completely close the crimping pliers.

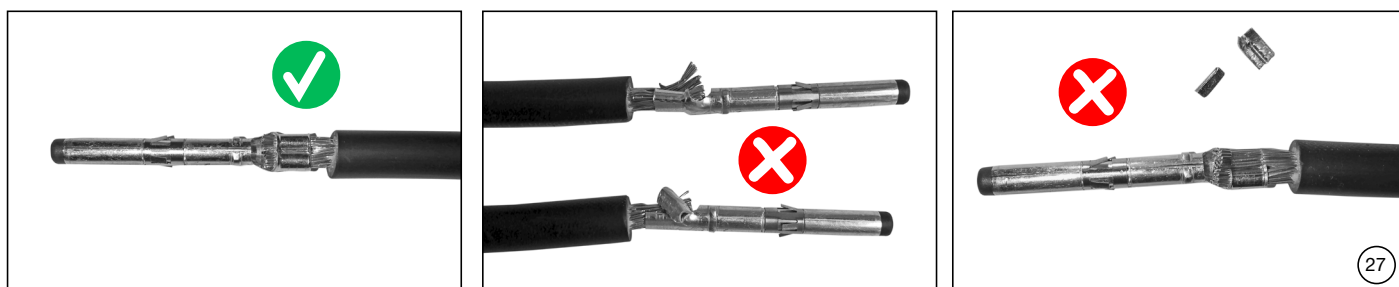

(ill. 27)

Crimpung kontrollieren bezüglich der Kriterien, die in IEC 60352-2:2006 + A1:2013 beschrieben sind.

Bestätigen dass:

- alle Litzen in der Crimphülse eingeschlossen sind
- die Crimphülse nicht deformiert ist und kein Teil der Crimplaschen fehlt
- die Crimpung symmetrisch ist
- auf der Kontaktseite der Crimpung ein „Bündel“ aus Litzen sichtbar ist.

Crimphöhe verifizieren. Typische Werte für die Crimphöhe der Stäubli PV Kabel Flex-Sol-Evo TX und Flex-Sol-Evo DX sind wie folgt:

(ill. 27)

Visually check the crimp according to the criteria written in IEC 60352-2:2006 + A1:2013

Confirm that:

- All of the strands have been captured in the crimp sleeve
- The crimp sleeve is not deformed or missing any portion of the crimp flaps
- That the crimp is symmetrical in form
- A “brush” of conductor strands are visible on the contact side of crimp.

Verify crimp height. Typical values for the crimp height for Stäubli PV cable Flex-Sol-Evo TX and Flex-Sol-Evo DX are listed below:

MC4	MC4-Evo 2	mm ²	AWG	Offener Crimpkontakt (B-Crimp) Open barrel crimp (B-Crimp)	Geschlossener Crimpkontakt (O-Crimp) Closed barrel crimp (O-Crimp)	Kabel Cable	Crimphöhe Crimp height
PV-KBT4/2,5...-UR PV-KST4/2,5...-UR	PV-KST4-EVO 2/2.5...-UR PV-KBT4-EVO 2/2.5...-UR	2.5	14	•		Flex-Sol-Evo TX 2,5 Flex-Sol-Evo DX 2,5	1.80
PV-KBT4/6...-UR PV-KST4/6...-UR	PV-KST4-EVO 2/6...-UR PV-KBT4-EVO 2/6...-UR	4.0	12	•		Flex-Sol-Evo TX 4,0 Flex-Sol-Evo DX 4,0	2.15
PV-KBT4/6...-UR PV-KST4/6...-UR	PV-KST4-EVO 2/6...-UR PV-KBT4-EVO 2/6...-UR	6.0	10	•		Flex-Sol-Evo TX 6,0 Flex-Sol-Evo DX 6,0	2.40
PV-KBT/10... PV-KST/10...	PV-KST4-EVO 2/10...-UR PV-KBT4-EVO 2/10...-UR	10	8	•		Flex-Sol-Evo TX 10 Flex-Sol-Evo DX 10	3.02
PV-KBT4/5...-UR PV-KST4/5...-UR			14		•	Flex-Sol-Evo DX 2,5	2.20
PV-KBT4/5...-UR PV-KST4/5...-UR			12		•	Flex-Sol-Evo DX 4,0	2.50
PV-KBT4/5...-UR PV-KST4/5...-UR			10		•	Flex-Sol-Evo DX 6,0	2.50
PV-KBT4/8II-UR PVKST4/8II-UR			8		•	Flex-Sol-Evo DX 10	3.12

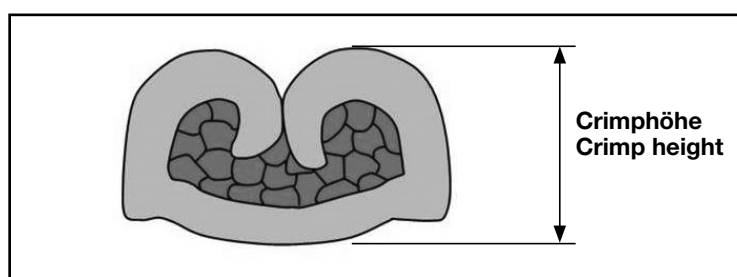

Gute Crimpverbindung

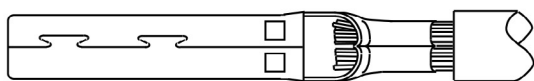

Good crimp

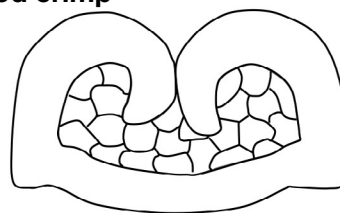

Schlechte Crimpverbindung:

- Stanzteile in falsche Richtung gebogen

Bad crimp:

- Stamped parts bent wrongly

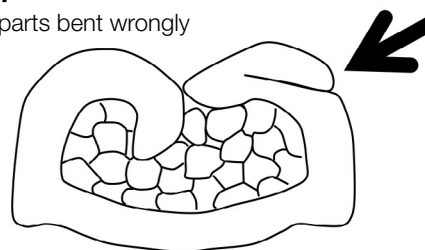
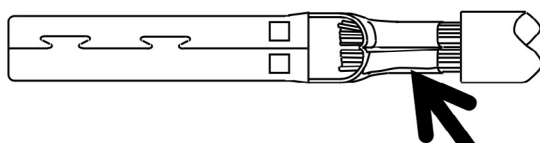

- Werkstoff nach unten geflossen („Flügel“)

- Material flow outwards

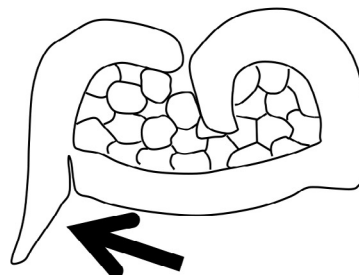
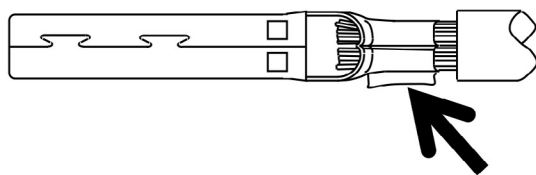

- Crimpverbindung nicht geschlossen

- Open crimp wings

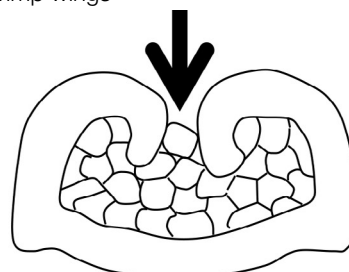
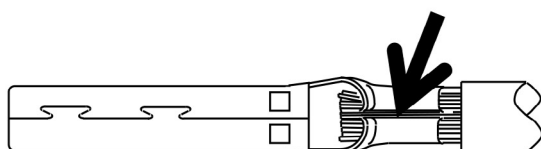

- Nicht gecrimpte Kabellitzen

- Not included strands

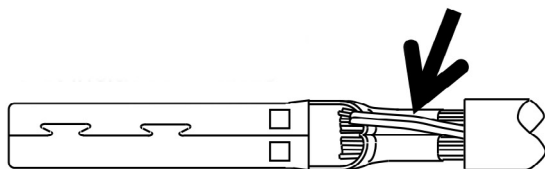

Hersteller/Producer:
Stäubli Electrical Connectors AG

Stockbrunnenrain 8
4123 Allschwil/Switzerland
Tel. +41 61 306 55 55
Fax +41 61 306 55 56
mail ec.ch@staubli.com
www.staubli.com/electrical